

# Orcan

Trusted Since 1978

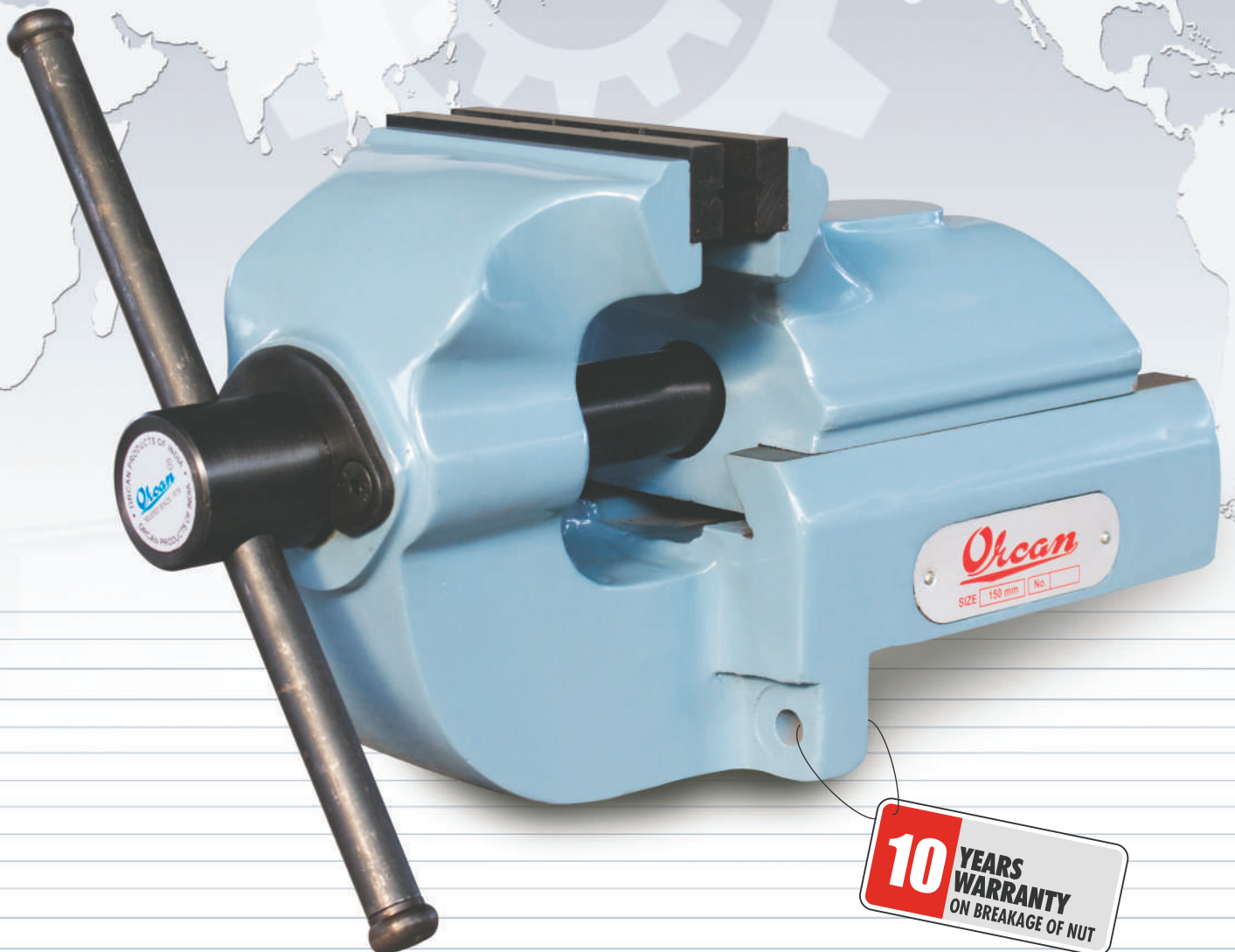

**10** YEARS WARRANTY  
ON BREAKAGE OF NUT

# ROCK SOLID GRIP

# PRODUCTS

## REAR JAW SLIDING BENCH VICE



Unique rear jaw movement design eliminates breakage in front jaw, saves valuable space towards operator as front jaw is stationary. Right angle machined mounting surfaces with two hole in front and one at back eliminates shaking and swivelling of vice.

Jaw Width	Jaw Opening	Depth Of Throat	Weight in Kg
3/75 mm	75 mm	30 mm	2.5
4/100 mm	115 mm	45 mm	8
5/125 mm	150 mm	65 mm	17
6/150 mm	200 mm	75 mm	30
8/200 mm	270 mm	80 mm	41

### KEY BENEFITS

- Dove tail sliding guide ways ensure jib less jaw alignment.
- Enclosed thread rolled screw in steel forging nut ensures reliable, maintenance free, durable operations.
- Hardened and ground jaws with 2 vertical and one horizontal V-grooves to clamp cylindrical jobs etc.
- Interchangeability of spare parts.
- Warranty: One year against manufacturing defects on size 3" & 4". Three years against all kind of breakage on 5", 6" & 8".

## DROP FORGED BENCH VICE

Jaw Width	Jaw Opening	Depth Of Throat	Weight in Kg
4"/100 mm	110 mm	75 mm	8
5"/125 mm	160 mm	90 mm	11.8
6"/150 mm	200 mm	105 mm	18.3

### KEY BENEFITS

- Vice available with replaceable jaws.
- Also available with pipe clamp jaws.
- Swivel base available (Completely made on CNC machine).
- Vice body is forged from SAE 1040 steel.
- Prismatic guide machined at top and bottom for absolutely parallel and precise movement.
- All critical operations are done on machining centre in one go for high accuracies.



## ←← BABY VICE

When you need to clamp the small work piece at workplace, in your Lab or hobby room Orcan baby Vice is the right choice, its light weight alluminium construction & easy to mount knob using and carrying it a childs play.



# MACHINE VICE FOR CNC VMC-MACHINES



★ ★ ★  
 WE ALSO MAKE  
 CUSTOMISED VICES  
 TO SUIT YOUR MACHINE/ WORK  
 PIECE REQUIREMENTS  
 ★ ★ ★

## DOVE TAIL MACHINE VICE

◀◀ **HEAVY DUTY**

Jaw Width	Jaw Opening	Depth Of Throat	Weight in Kg
6"/150 mm	190 mm	70 mm	35
8"/200 mm	300 mm	72 mm	59.5

### KEY BENEFITS

- Dove tail guide-ways will ensure there is no job uplift during clamping and machining.
- All parts are made out of SAE-1040/C.I.Castings.
- Option of machine vice & self centering vice.
- Clamping jaws can be customized to hold round jobs.
- Jaw width & jaw opening can be manufactured as per the customer requirement.

**LIGHT DUTY** ▶▶

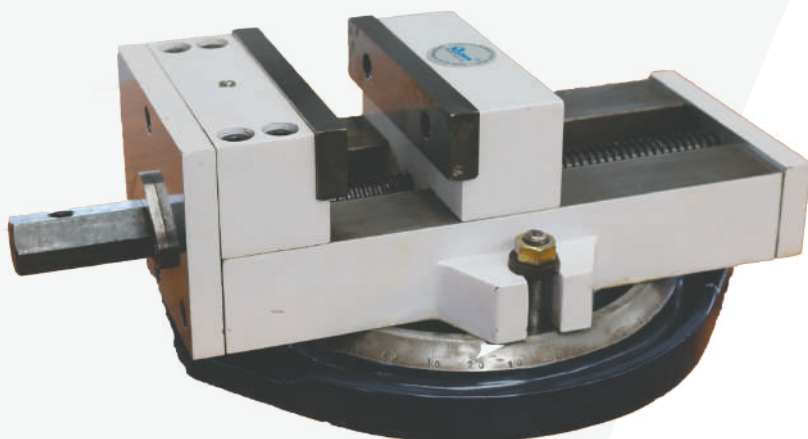

Swivel base optional

Jaw Width	Jaw Opening	Depth Of Throat	Weight in Kg
4"/100 mm	130 mm	37 mm	14/20.7
5"/125 mm	175 mm	40 mm	17
6"/150 mm	175 mm	60 mm	26/37.2

## TWIN JOB CLAMPING >>

Jaw Width	Jaw Opening	Depth Of Throat	Weight in Kg
4"	100 mm	36 mm	20
6"	100 mm	72 mm	42

Twin Job clamping has the heavy duty construction with dove tail guideways. The vice increase the VMC output by dividing tool change and job change timings of a cycle by the factor of 2. the stopper plate can be mounted on either side of the vice.

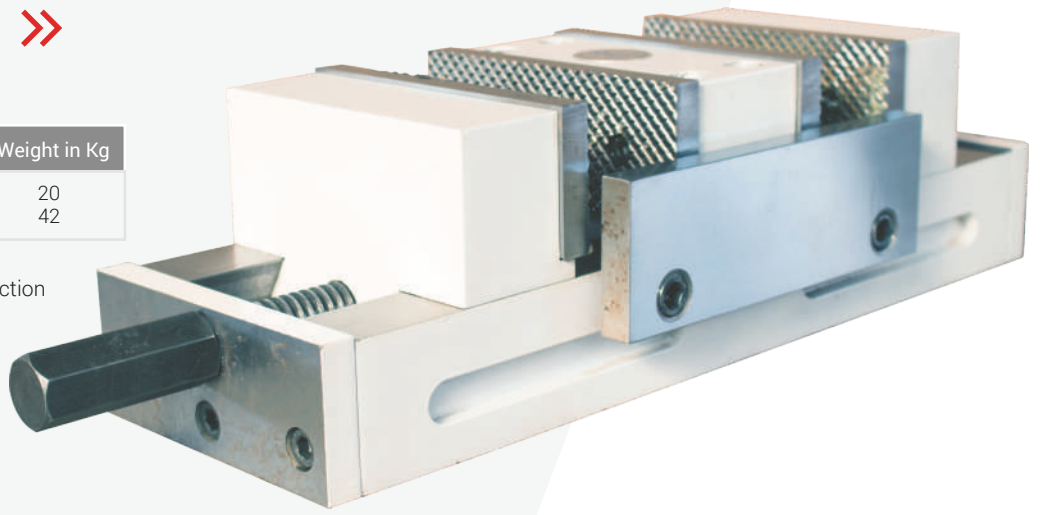

## << GRINDING VICE

Jaw Width	Jaw Opening	Depth Of Throat	Weight in Kg
70 mm	115 mm	34 mm	8.2

It can be used on bottom as well as left and right side face. When clamped to the machine using side slots, it can as well be used on light milling applications.

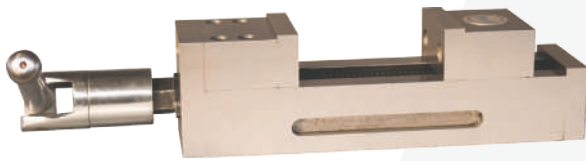

## QUICK ADJUST MACHINE VICE

Jaw Width	Jaw Opening	Depth Of Throat	Weight in Kg
10"/250 mm	420 mm	75 mm	160

It's robust and accurate, quick adjustment is made possible by engaging Pin in various positions.

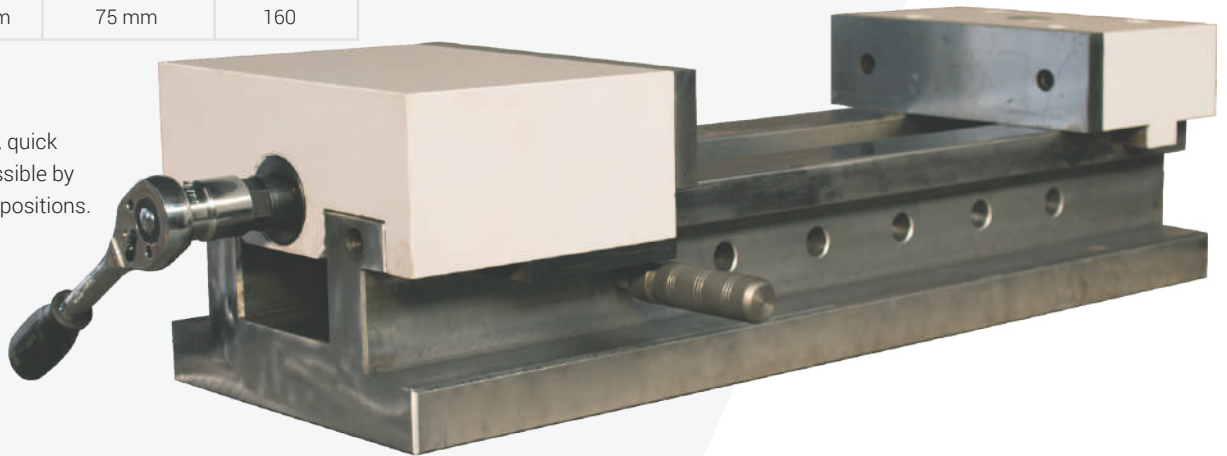

### KEY BENEFITS

- Eliminates jaw and work lift.
- Higher clamping power.
- Rigid steel parts for better life.
- Simple mechanism and trouble free.
- Ground top and bottom of vice base for parallelism.
- Optional Accessories - Swivel base & Universal handle.

Jaw Width	Jaw Opening	Depth Of Throat	Weight in Kg
4"/100 mm	100 mm	29 mm	15/21.5
6"/150 mm	200 mm	44 mm	35.5/46.7

## PRECISION MACHINE VICE

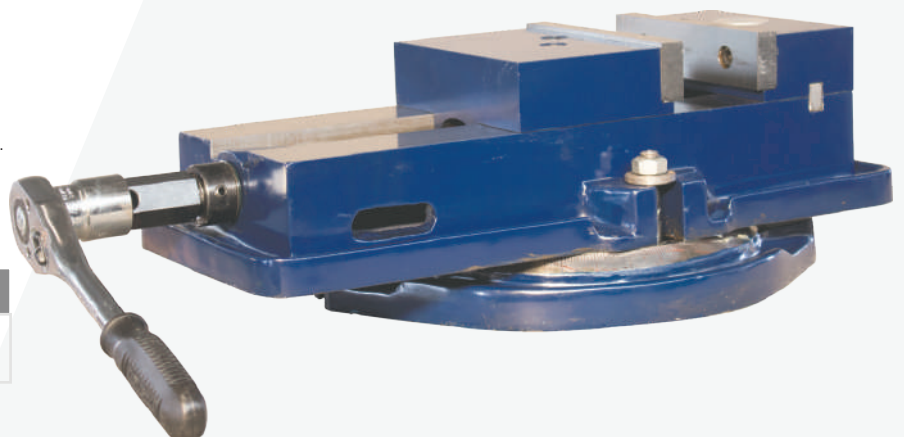



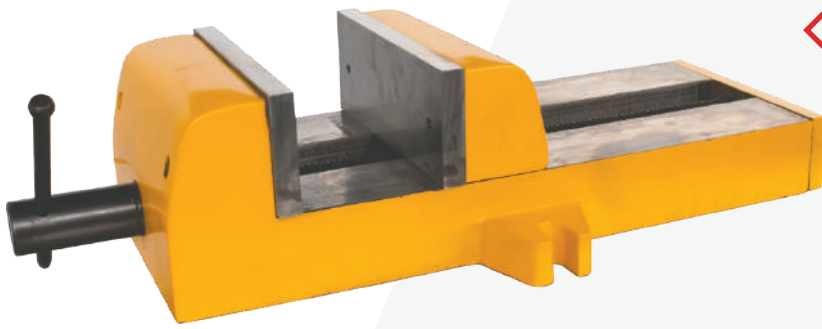

## « MULTIPURPOSE MACHINE VICE

Orcan presents Deep Throat Multi Purpose Vice. As the name suggests it is a multi purpose vice which can be employed for various machining operations such as milling, drilling, surface grinding etc. The advantage we get in this vice is its extra deep throat to clamp big components. We offer this vice in 200 mm (8). Pneumatic version also available.

Jaw Width	Jaw Opening	Depth Of Throat	Weight in Kg
6 In/150 mm	200 mm	81 mm	31.5
8 In/200 mm	300 mm	84 mm	39.6

## PNEUMATIC MACHINE VICE

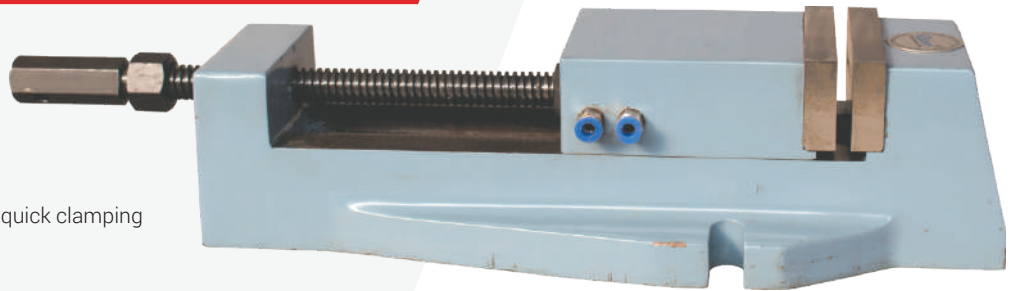

### KEY BENEFITS

- Gripping through manual screw adjustment and quick clamping through Pneumatic Machine Vices.
- In-built sophisticated piston mechanism.
- Clamping power of 4500 N at 7 bar (100 psi) air pressure.
- Grounded and hardened tool steel jaws for perfect parallelism.
- Steel moving jaw rules out pressure drop and air leakage.

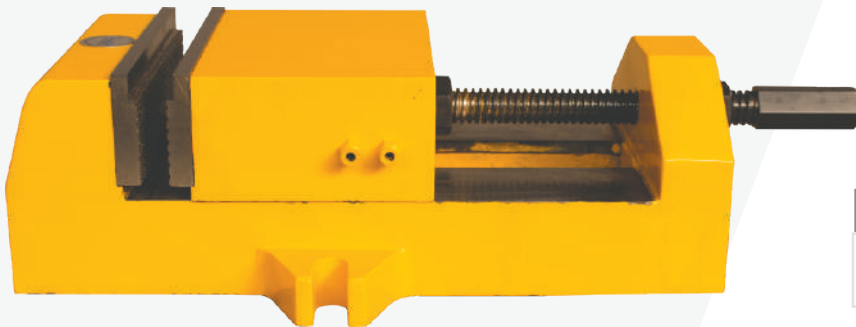

Jaw Width	Jaw Opening	Depth Of Throat	Weight in Kg
100 mm	95 mm	29 mm	15.4
200 mm	150 mm	75 mm	45

## « BEARING PULLER VICE

The unique designed bearing seat, at one end of the jaws holds bearing along with the armature shaft. The screw is held by the square nut opposite to the bearing seat. The screw is rotated towards the bearing, which effortlessly removes the shaft from bearing. The convenience, can only be experienced!

Jaw Width	Jaw Opening	Depth Of Throat	Weight in Kg
100 mm	80 mm	65 mm	8.6

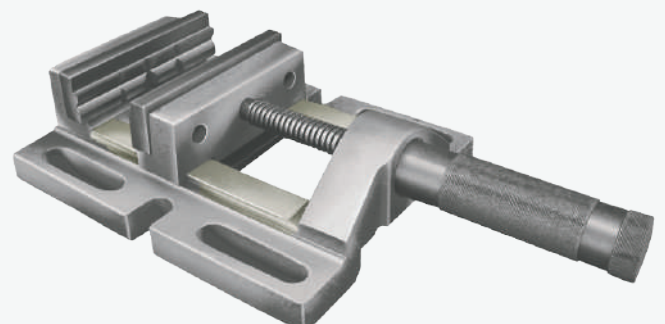

## DRILL PRESS VICE UNI GRIP TYPE »

Jaw Width	Jaw Opening	Depth Of Throat	Weight in Kg
5/125 mm	108 mm	40 mm	7.0



Trusted Since 1978

## ABOUT US

At Orcan we design & manufacture Bench vices & machine vices, with dedication and commitment to offer the products which meets the technical ,commercial & delivery requirements of our Clients.

The objective of Good quality is met, by our dedicated manufacturing workforce & Design team .The modern Engineering practices are used everywhere in our plant to keep the Production procedures relevant to today's customer demand, be it manufacturing or packaging the emphasis is given to protect the quality of the product & keep the cost of production to optimum level.the energy & environment conservation is becoming integral part of our work philosophy.

The result of our efforts is reflected in the happiness our customers have using our products due to product Reliability,Durability & ease of use .We focus on making things easier for our clients in terms of ordering ,supplies & spare parts.

## CLIENTS



### ENGINEERING COLLEGES

B.V.B College Of Engineering & Technology, Hubli  
Geedee Technical Training Institute, Coimbatore  
Gkitr Institute For Technological, Coimbatore  
Indo Canadian School Of Training, Faridabad  
Indo German Tool Room, Aurangabad  
K.L.E. Society's Belgaum  
Manav Rachna College Of Engineering, Faridabad  
Nttf Technical Training Center, Bangalore  
T.S. Srinivasan Vocational Training Center, Chennai  
Vivekanada Scientific & Engg., Hubli

*As our client you would be in good company*



### INDUSTRIAL CUSTOMERS

ACE Designers Ltd.  
GKN Drive Shafts Ltd.  
Groz-Beckert & Grob Horgen AG  
Hero Honda Motors Ltd.  
Integral Coach Factory  
JCB India Ltd.  
Mahindra & Mahindra Ltd.  
Mitsubishi Electric Automotive India Pvt Ltd.  
Skytech Engineering  
The TVS Group  
Whirpool India Ltd.



## ORCAN PRODUCTS OF INDIA

Plot no. 51, Industrial Area, N.I.T. Faridabad - 121 001 (Haryana) India  
Tel. : +91-129-4033248, 4032248, 4021748, 2238862,  
Mobile: +91-9811043930, 9810140136  
E-mail : mktg@orcan.com, orcan.paul@gmail.com

**Website : [www.orcan.com](http://www.orcan.com)**